



MTH

Multijet meter
for hot water up to 130 °C
DN 15, 20, 25, 32, 40, 50
PN 16/25

Your benefits

- Robust, high grade wear resistant materials:
Excellent measuring stability and reliability
- Measurement of low flow rates:
Increased cost effectiveness

Application

- The multijet hot water meter is suited for central heating installations and district heating applications or for solar installations.

Features

- Multijet impeller wheel, super dry-dial with magnetic coupling
- Register can be turned for best readout position
- Maximum operating pressure PN 16 (Threaded) / PN 25 (Flanged)
- Maximum operating temperature 130°C
(can be overloaded to 150°C for short period of time)
- Horizontal or vertical (MTH-V...) installation
- Flanged configuration only for horizontal installation
- Reed pulser IPG14 with 1,5m cable
- High grade wear resistant and corrosion proof materials
- Inlet strainer
- Reconditionable and recyclable execution
- Magnetic protective cover against external influences
- Swiss Approval and PTB Type Approval according to EN 1434
- **CE** Conformity according to European Measuring Instruments Directive (MID)
- Environmental class B, Accuracy class 3

Options

- Flanged variant PN 16 and PN 25
- Reed pulser IPG14 with 5m cable
- US Gallon register
- NPSM threaded connection (only for horizontal housing)
- Different pulse values
 Documentation: IPG14 - EPe40217

Technical Data

Execution			MTH (horizontal)							MTH-VS or -VF (vertical) ¹⁾			
Nominal diameter	DN	mm	15	20	25	25	32	40	50	20	25	32	40
Operating pressure	PN	bar	16	16	16	16	16	16	16	16	16	16	16
Operating pressure (flanged)	PN	bar	-	25	25	25	25	25	25	-	-	-	-
Connection thread on meter	G...B	Inch	¾	1	1¼	1¼	1½	2	2¾	1	1¼	1½	2
Connection thread on coupling	R...	Inch	½	¾	1	1	1¼	1½	2	¾	1	1¼	1½
Nominal flow rate	q _p	m³/h	1,5	2,5	3,5	6	6	10	15	2,5	3,5	6	10
Maximum flow rate	q _s	m³/h	3	5	7	12	12	20	30	5	7	12	20
Minimum flow rate	q _i	l/h	60	50	70	120	120	200	300	50	70	120	200
Kvs-value		m³/h	3,5	5	10	12	12	20	30	5	10	12	20
Temperature range		°C	2... 130	2... 130	2... 130	2... 130	2... 130	2... 130	2... 130	2... 130	2... 130	2... 130	2... 130
Measuring range	q _i / q _p		1:25	1:50	1:50	1:50	1:50	1:50	1:50	1:50	1:50	1:50	1:50

Dimensions and weights			MTH (horizontal)							MTH-VS or -VF (vertical) ¹⁾			
Length without couplings	A	mm	165	220 ²⁾	260	260	260	300	300	105	150	150	200
Length with couplings		mm	239	312	352	352	372	432	452	197	242	262	332
Total height	B	mm	127	133	143	143	143	169	183	-	-	-	-
Meter height from pipe centre line	C	mm	84	93	100	100	100	123	126	-	-	-	-
Meter depth	D	mm	-	-	-	-	-	-	-	148	169	183	226
Meter depth from pipe centre line	E	mm	-	-	-	-	-	-	-	130	143	156	190
Meter width	F	mm	95	95	100	100	100	135	151	95	98	101	139
Length with flanges PN 16/25		mm	-	190	260	-	260	300	300 ³⁾	-	-	-	-
Height with flanges	H	mm	-	140	152	-	162	192	204	-	-	-	-
Flange external dimension ⁴⁾		mm	-	105	115	-	140	150	165	-	-	-	-
Hole circle diameter ⁴⁾		mm	-	75	85	-	100	110	125	-	-	-	-
Number of screws ⁴⁾	Pcs.		-	4	4	-	4	4	4	-	-	-	-
Weight without couplings		app. kg	1,8	2,1	2,7	-	2,8	5,3	5,8	-	-	-	-
Weight without couplings MTH-VS		app. kg	-	-	-	-	-	-	-	2,0	2,3	2,3	5,8
Weight without couplings MTH-VF		app. kg	-	-	-	-	-	-	-	2,1	3,5	3,7	7,1
Weight with couplings		app. kg	2,1	2,4	3,2	3,2	3,5	6,4	7,4	-	-	-	-
Weight with couplings MTH-VS		app. kg	-	-	-	-	-	-	-	2,3	2,8	3,0	6,9
Weight with couplings MTH-VF		app. kg	-	-	-	-	-	-	-	2,4	4,0	4,4	8,2
Weight with flanges		app. kg	-	3,8	5,0	-	5,0	9,9	10,4	-	-	-	-

¹⁾ -VS = vertical riser / -VF = vertical down pipe
⁴⁾ DIN EN 1092-2

²⁾ Also supplied in length 190mm

³⁾ Also supplied in length 270mm

Dimension Diagram

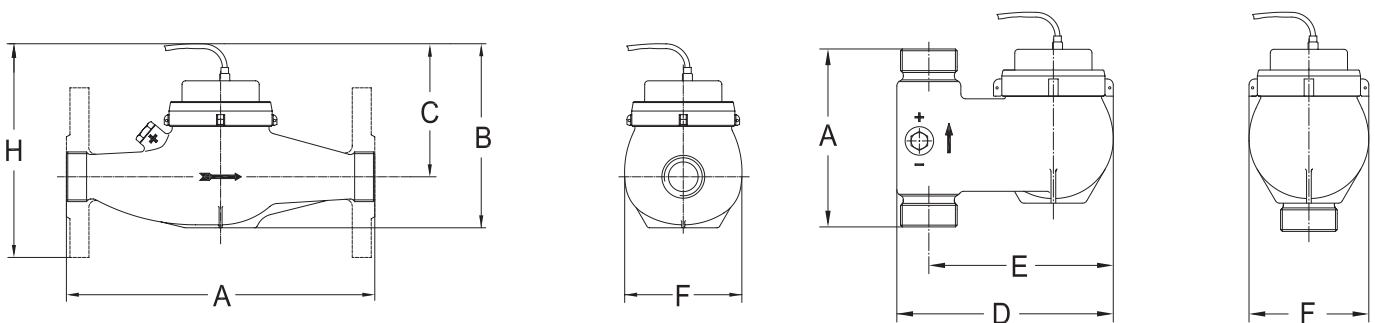

Materials

Housing with screwed connection:	UBA Brass (DIN 50930-6)
Housing with flanged connection:	Cast iron
Sealing plate:	UBA Brass (DIN 50930-6)
Impeller / head piece:	High grade synthetic material
Bearings:	Hard metal, sapphire, Chrome nickel steel
Seal material:	EPDM

Typical Head Loss Curve

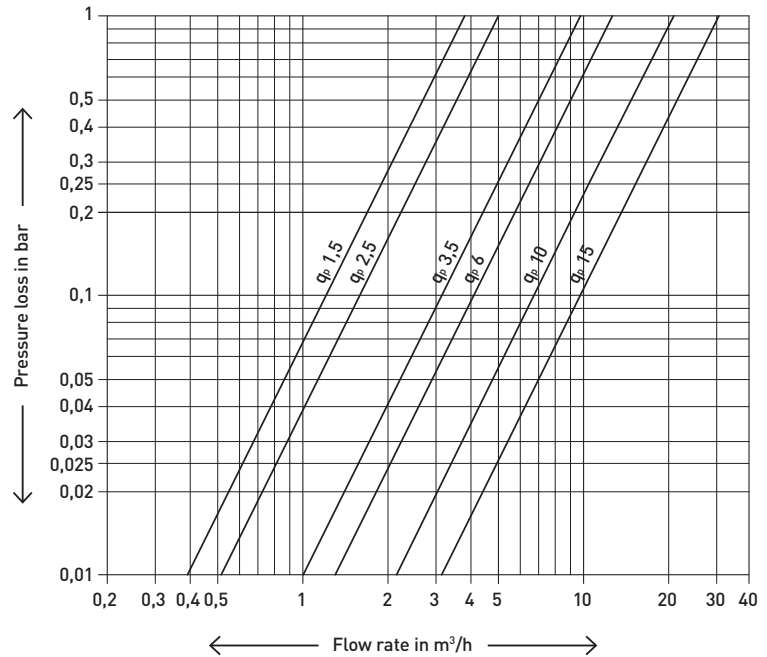

Installation

Pipeline:	horizontal	—
	vertical	
Meter head:	upwards	↑

Pulse value table

Pulse values (1 Pulse = ... Liter)	q_p	1,5-6	1*	2,5	10	25	100	250
	q_p	10-15	-	2,5	10	25	100	250
Pulse values (1 Pulse = ... US Gallons)	q_p	1,5-6	1	-	10	-	100	-
	q_p	10	-	-	10	-	100	-

* Only available in measuring range 1:25 without approvals

GWF MessSysteme AG
Obergrundstrasse 119
6005 Lucerne, Switzerland

T +41 41 319 50 50
F +41 41 310 60 87
info@gwf.ch, www.gwf.ch

Technical support:
T +41 41 319 52 00, support@gwf.ch

printed in
switzerland

Subject to modification, 23.08.2018 – EPe20311